

Namco-America, Inc.



Operators Manual

STARBLADE™ Operators Manual

SCAN BY DARTH NUNO
VISIT MY STARBLADE PAGE
AT
WWW.DRAGONSLAIRFANS.COM



CONTENTS

1. SPECIFICATIONS	1
2. PRECAUTIONS	
2-1 Installation Precautions	1
2-2 Handling Precautions	2
3. INSPECTION	2
4. INSTALLATION	
4-1 Seat Base	3
4-2 Monitor Cabinet	3
4-3 Seat Assembly	4
4-4 Level Adjustments	4
4-5 Power and Final Setup	4
5. ADJUSTMENTS	
5-1 Power Switch	5
5-2 Adjustment Switches on the Service Panel	5
5-3 Test Mode	5
5-3-1 Main Test Menu	6
5-3-2 Game/Coin/Option Screen	6
5-3-3 Switch Test Screen	7
5-3-4 Sound Test Screen	8
5-3-5 Effect Test Screen	8
5-3-6 Monitor Test Screen	9
5-3-7 Object Test Screen	10
5-3-8 ADS Screen	10
5-4 DIP Switches	10
5-5 Monitor Adjustment	11
5-6 Gun Adjustment	11
6. HOW TO PLAY	12
7. MAINTENANCE	
7-1 Marquee and Fluorescent Lamp Replacement	13
7-2 Gun Assembly Replacement	13
7-3 Hemispherical Mirror Replacement and Cleaning	14
7-4 Vibration Assembly Replacement	14
7-5 Game PC Board Removal	14
7-6 Monitor Board Access	15
7-7 Monitor Tube Removal	15
7-8 Strobe Lamp Replacement	15
8. TROUBLESHOOTING	16
9. PARTS LIST	17
10. GAME WIRING HARNESS DIAGRAM	26-27
11. LIST OF ILLUSTRATIONS (see over)	

CONTENTS (cont.)

11. LIST OF ILLUSTRATIONS

4-1	3/4 View of Game	3
5-1	Service Panel	5
5-2	Gun Assembly	5
5-3	Test Menu Screen	6
5-4	Game Option Screen	6
5-5	Switch Test Screen	7
5-6	Sound Test Screen	8
5-7	Effect Test Screen	9
5-8	Monitor Test Screen	9
5-9	Object Test Screen	10
5-10	ADS Menu Screen	10
5-11	Monitor Remote Adjustment Board	11
5-12	Gun Aiming Screens	11
7-1	Gun Assembly Replacement	13
7-2	Vibration Assembly Replacement	14
9-1	Vibration Assembly	21
9-2	Gun Assembly (exploded view)	22
9-3	Coin Assembly (exploded view)	24
x-x	Game Wiring Harness Diagram	26-27

STARBLADE™

1. SPECIFICATIONS

POWER SUPPLY:	UL Listed PC XT Type Switching Power Supply		
POWER CONSUMPTION:	Total 240 W		
MONITOR:	One standard 25" Color Monitor with auto-degauss and remote adjustment board		
DIMENSIONS (assembled):	Width	Depth	Height
	43.5"	77.5"	81"
CRATED DIMENSIONS:	Width	Depth	Height
Mirror Cabinet	49"	40"	79.5"
Seat Assembly	41"	61"	51.5"
Monitor Cabinet	36"	32"	39"
SHIPPING WEIGHTS:	Mirror Cabinet	Seat	Monitor Cabinet
	478 lbs.	236 lbs.	172 lbs.
ACCESSORIES:	Keys:		
	Coin Box		2
	Coin Door		2
	Rear Door		1
	Security Wrench		1
	3/4" box end wrench		1
	Instruction Manual		1
	Instruction Card		1

Note: Specifications may change without prior notice.
Modification and/or alteration of the
STARBLADE™ game with kits or parts not
supplied by NAMCO may void the warranty.

2. PRECAUTIONS

2-1 Installation Precautions

This game is designed for indoor use only. It should not be installed outdoors or under the following conditions:

- In areas directly exposed to sunlight, high humidity, direct water contact, dust, high heat or extreme cold.
- In locations that would present an obstacle in case of emergency, i.e. near fire equipment or emergency exits.
- On an unstable surface or floor subject to other vibration.

2-2 Handling Precautions

- a. Do not subject game to physical shock when transporting or moving it.
- b. The cabinet should be grounded with a securely connected ground line.
- c. The monitor includes areas of high-voltage. Care should be taken at all times to avoid electrical shock whenever inspecting or adjusting the game.
- d. When unplugging the game from an electrical outlet, always grasp the plug, not the cord.
- e. Power should always be turned off before replacing any parts.
- f. DO NOT attempt to repair the Printed Circuit Board (PCB) on site. It contains sensitive integrated circuit chips that could easily be damaged by even the small internal voltage of a multi-meter. Always return the PCB to your distributor for any repairs.
- g. Always return the leg levelers to the extreme "up" position before moving the game.
- h. Adjustment is required whenever the game PC board, ROM, gun assembly or volume control is changed. (ref. sec. 5-6, Gun Adjustment)
- i. Exercise caution to prevent scratching the hemispherical mirror located within the cabinet.

3. INSPECTION

The STARBLADE™ Game should be carefully inspected upon receipt to insure that it is complete and was delivered in good condition by doing the following:

1. Examine the cabinet exterior for dents, cracks, or broken parts.
2. Inspect the monitor cabinet for dents, cracks, or broken parts.
3. Inspect the seat assembly for punctures, cracks, or other damage.
4. Open the rear doors and;
 - a. Verify that all plug-in connectors (on the cabinet harness) are firmly plugged in. DO NOT force connectors together. The connectors are labeled to assure the proper orientation. A reversed edge connector can damage a PCB and will void your warranty.
 - b. Inspect the power cord to insure that there are no cuts or dents in the insulation.
 - c. Inspect the power supply connectors.
 - d. Inspect all other major sub-assemblies, such as the hemispherical mirror, strobe lights, PCBs, etc. Make sure that they are mounted securely and that all ground wires are firmly connected.
5. Read section 4 and check for missing parts or fasteners.

4. INSTALLATION

Allow yourself about 2 to 3 hours for proper assembly of STARBLADE™. A minimum of 3 people are needed to install the monitor cabinet (step 4-2 takes about 30-45 minutes).

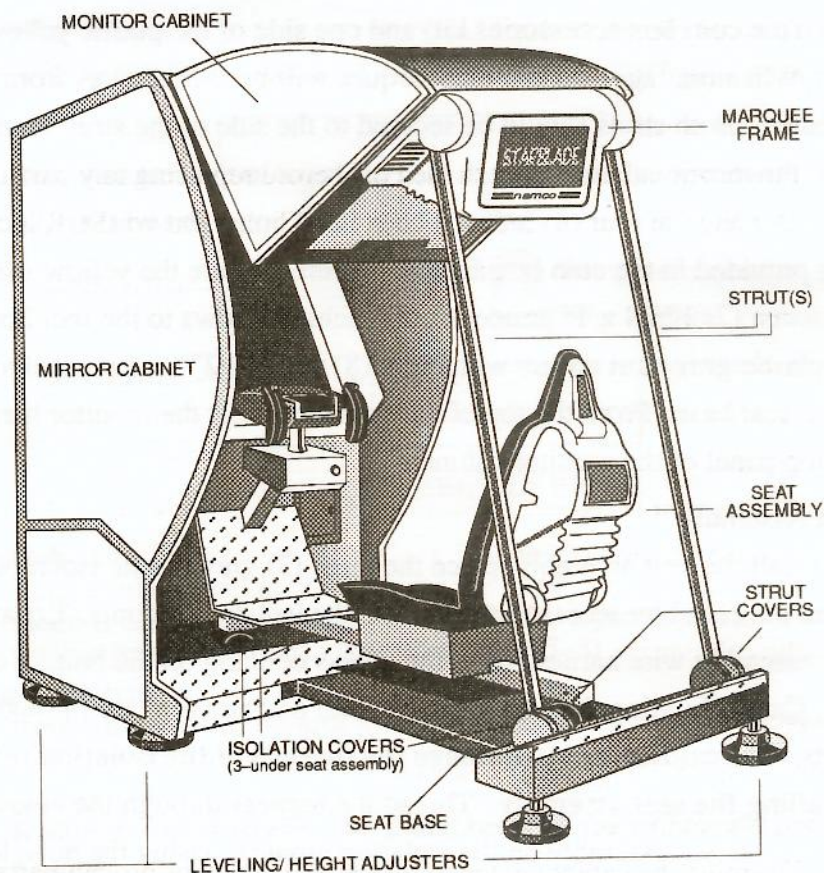

Illustration 4-1, 3/4 VIEW

4-1 Seat Base

To install the seat base, locate the wire harness coming out of the front floor of the mirror cabinet and line up the holes on the seat base brackets with the holes in the mirror cabinet. Carefully feed the wire harness through the hole provided in the seat base, then screw in and tighten the base using the four (4) black 5/16" x 1 1/2" hex head bolts and washers provided (from the coin box accessories kit).

4-2 Monitor Cabinet

CAUTION - THE MONITOR CABINET IS VERY HEAVY AND REQUIRES A MINIMUM OF THREE (3) PEOPLE TO SAFELY INSTALL.

Before installing the monitor cabinet, insure that the mounting bracket and monitor openings are clear of any obstructions. Also insure that the seat base has been properly installed and secured. **Failure to install the seat base first can cause the mirror cabinet to be unbalanced and fall.** Remove the top panel of the monitor cabinet by removing the four (4) phillips head screws retaining the 32" x 27" panel. Carefully lift the monitor cabinet and lower it onto the support bracket on the top of

the monitor opening of the mirror cabinet. Using the four (4) 5/16" x 1 1/2" black hex head bolts and washers provided in the coin box accessories kit, secure the monitor cabinet in place from the inside of the mirror cabinet. The 66" metal struts are mounted with the slotted hole attached to the seat base. Slide one strut cover (from the coin box accessories kit) and one side of the plastic yellow marquee frame over each strut. Be sure that the marquee will be facing away from the game once installed. Both struts should be secured to the side of the strut mount furthest away from the mirror cabinet. Attach the two struts to the seat base and monitor cabinet mounts using the four (4) 3/8" x 1" hex head bolts, flat washers, lock washers and nuts provided in the coin box accessories kit. Secure the yellow marquee frame with the seven (7) 10/24 x 1" tamperproof machine screws to the monitor cabinet. Attach the plastic grey strut covers with eight (8) #10 x 1/2" tamperproof sheet metal screws to the seat base. From the top of the game, connect the monitor harness and resecure the top panel of the monitor cabinet.

4-3 Seat Assembly

To install the seat assembly, place the three (3) grey plastic isolation mount covers (from the coin box accessories kit) onto the isolation mounts. Locate and extend the seat assembly wire harness from the access opening on the bottom of the seat assembly. Carefully bring the seat assembly into position directly through the support struts. **Use caution not to damage the threads of the isolation mounts when installing the seat assembly.** Thread the harness through the hole in the seat base and set the seat assembly on the isolation mounts. Using the nuts, lock washers and the 3/4" box wrench provided, secure the seat assembly to the isolation mounts. There are three (3) yellow end caps that are secured by two (2) black phillips head screws each to cover the open ends. Connect the two plugs of the seat assembly harness underneath the seat base and secure the harness with the mounts provided. Neatly pack the excess harness above the front wheel mount on the seat base.

4-4 Level Adjustments

Each STARBLADE™ game has six (6) leveling/height adjusters – one on each corner of the mirror cabinet and two on the back of the seat assembly. It is important to lower all leg levelers to provide a stable, shock absorbing cabinet.

4-5 Power and Final Setup

Plug the power cord into the game and the AC outlet. If the game doesn't come on right away, press the power switch on the lower left side of the cabinet. If the game still does not operate, call your distributor or NAMCO Customer Service. Adjust the game/gun controls (see section 5-6) to insure proper operation. Change the game settings for your location (see section 5-3-2). Turn off the test switch and play the game to confirm your settings.

5. ADJUSTMENTS

5-1 Power Switch

When installation is complete, connect the power cord to an AC outlet and turn the power on. The power switch is located on the lower left side of the mirror cabinet.

5-2 Adjustment Switches

Open the upper coin door to gain access to the service panel.

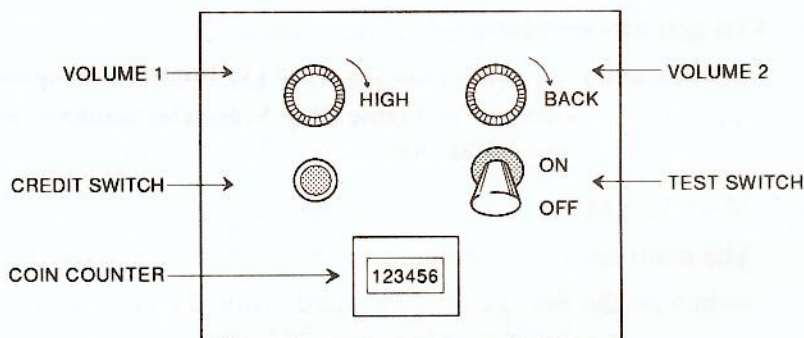

Illustration 5-1, SERVICE PANEL

Test switch

Toggle this switch to "ON" to put the game into the test mode. The test mode is used to change the fee charged for a game, and to set and test various game functions. (see illustration 5-3)

Volume 1 control

Rotate the volume control to adjust speaker sound level for your location.

Volume 2 control

Rotate this knob to even the sound between the front and back speakers.

Credit switch

This switch is used to increase the number of credits without activating the coin counter.

5-3 Test Mode

Trigger buttons 1 through 4 on the Gun Assembly (illustration 5-2) are used to select the individual screens and various line item settings contained on each screen.

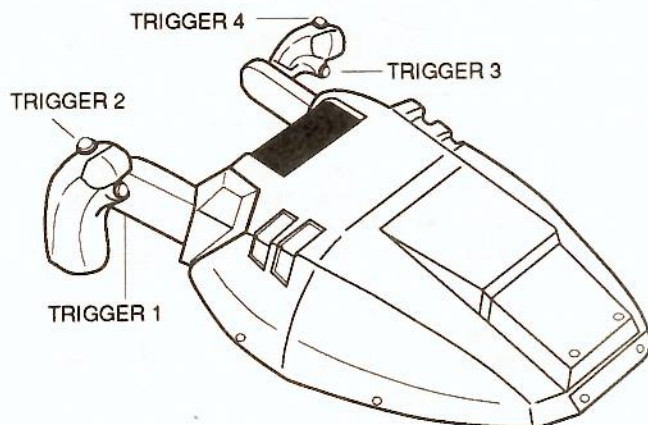

Illustration 5-2, GUN ASSEMBLY

Pressing trigger buttons "3" and "4" will change the selected (red) items and pressing trigger button "1" will display the selected test screen. While in any of the test screens:

Options can be selected by pressing trigger buttons "3" or "4".

Options can be activated by pressing trigger button "1".

Values of the selected options are INCREASED by moving the trigger handles LEFT and DECREASED by moving the trigger handles RIGHT.

To exit any screen, press trigger button "2".

When testing or option changes have been completed, turn the test switch to the "OFF" position. The Game Play Screen will always reappear from whatever test screen is being displayed at the moment.

5-3-1 Main Test Menu

The main test menu screen (illustration 5-3) is activated by using the test switch on the Service Panel located inside the coin door. There are seven separate test mode screens (listed here) which can be used to change game fees and test various functions of the game. Select the test to be performed by using the gun controls listed above.

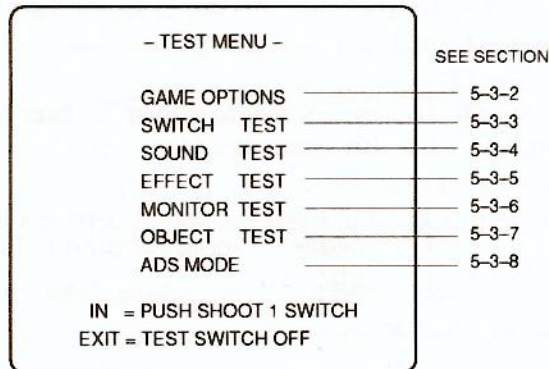

Illustration 5-3, TEST MENU SCREEN

5-3-2 Game/Coin Option Screen

After selecting the Game Option Screen (illustration 5-4), any one of nine different options can be changed using the gun controls.

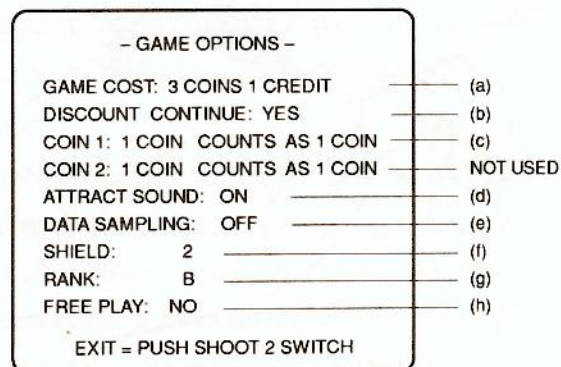

Illustration 5-4, GAME OPTION SCREEN

- (a) The Game cost can be from 1 to 9 coins per credit.
- (b) The half price to continue rounds up to the nearest whole number. (For example, 3 to start, 2 to continue: or 4 to start, 2 to continue).
- (c) The number of logical coins per physical coin can be adjusted from 1 to 9.
- (d) The attract sound can be turned "ON" or "OFF" (we suggest "ON").
- (e) The "ADS MODE" (bookkeeping) option can be removed from the Main Test Menu by selecting "OFF". **No bookkeeping will be kept if this option is "OFF"**
- (f) The Shield damage level can be adjusted between 1 (easy) and 8 (hard).
- (g) The difficulty (Rank) can be adjusted between "A" (easy) and "D" (hard).
NOTE: Adjusting the Shield Damage (f) is more effective than adjusting the Rank (g).
- (h) The Free Play option can be turned "ON" or "OFF". The games will be tracked in the bookeeping as if they were paid games.

5-3-3 Switch Test Screen

The Switch Test Screen (illustration 5-5) provides test displays for all STARBLADE™ switches and potentiometers.

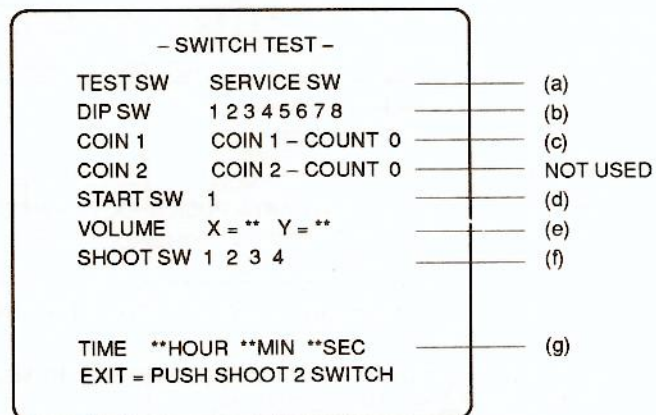

Illustration 5-5, SWITCH TEST SCREEN

- (a) When lighted red, "TEST SW" indicates a normal operation. "SERVICE SW" should turn red whenever the Credit switch, inside the coin door, is pressed.
- (b) The status of the DIP switch on the game PCB board (CPU-PCB) is indicated by this display. Any number opposite DIP SW (switch) that is lighted red indicates that it is turned on.
- (c) When the coin 1 switch is closed, "COIN 1" will turn red indicating proper operation. The number shown indicates the number of times the switch has been triggered. The coin counter will not advance.

- (d) When testing the Start Switch, the "1" should turn red whenever the start button is pressed.
- (e) This tests the operation of the gun potentiometer. Values **increase** when the gun is moved **up** or to the **right**, and **decrease** when its moved **down** or to the **left**.
Moving left and right will change the value X.
Moving up and down will change the value of Y.
- (f) When pressing a gun trigger, the appropriate number should turn red. (Pressing Trigger "2" will Exit this test and return you to the Main Menu).
- (g) This display indicates the amount of time the game has been on.

5-3-4 Sound Test Screen

The Sound Test Screen allows for selection and playing of specific sounds. This can be useful when replacing speakers or adjusting the stereo volume.

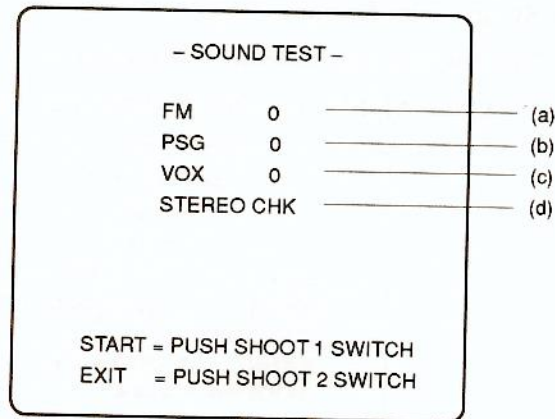

Illustration 5-6, SOUND TEST SCREEN

Use the gun controls, explained previously in section 5-3, to test the various sounds. Trigger "1" starts the selected sound.

- (a) The FM option tests "Filed Music" or digitally created sounds.
- (b) The PSG option tests both (a) and (c) combined. This is where most of the actual game play sounds are stored.
- (c) The VOX option includes digitally recorded sounds and voice.
- (d) When the STEREO CHK option is played, a tone scale is sent to the right speakers and then the left speakers.

5-3-5 Effect Test Screen

The Effect Test screen (illustration 5-7) tests the various mechanical mechanisms and lamps using the gun controls.

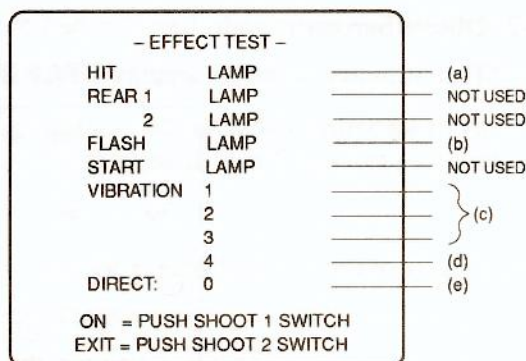

Illustration 5-7, EFFECT TEST SCREEN

- (a) Hit Lamp activates the LED's in the center of the gun when selected.
- (b) This option flashes both strobe lights (above the mirror) when selected.
- (c) Vibration 1, 2, and 3 momentarily activates the vibration assembly mounted on the back of the seat.
- (d) Vibration 4 continuously activates the vibration assembly until the trigger button is released. **CAUTION: Do not activate the motor continuously for more than 2 minutes.**
- (e) Direct (0 - FF) activates various combinations of effects (a) - (d).

5-3-6 Monitor Test Screen

DANGER HIGH VOLTAGE
THE MONITOR CONTAINS LETHAL HIGH VOLTAGE. THE MONITOR IS TO BE SERVICED BY A QUALIFIED SERVICE TECHNICIAN ONLY.

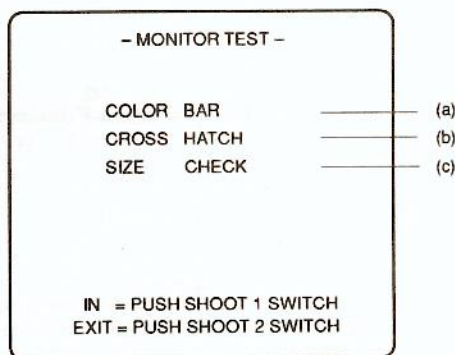

Illustration 5-8, MONITOR TEST SCREEN

- (a) **The Color Bar test** sends a pattern to the screen that is used to adjust the red, green, blue and brightness levels. Adjustment should not be necessary, but can be made by a qualified service technician.
- (b) **The Cross Hatch test** sends a grid to the screen to be used for adjusting the monitor convergence. Adjustment should not be necessary, but can be made by a qualified service technician.
- (c) **Size Check** sends a grid to the screen to be used for adjusting the monitor height, width, and position. Adjustment should not be necessary, but can be made by a qualified service technician.

5-3-7 Object Screen

This screen is used to display STARBLADE™ polygons and graphics.

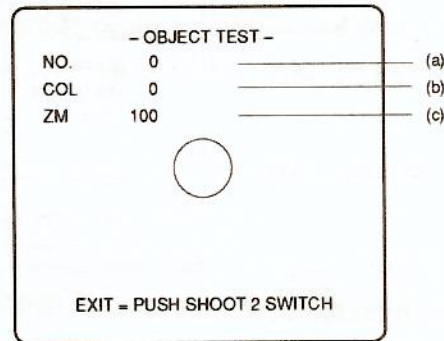

Illustration 5-9, OBJECT TEST SCREEN

- (a) This option is used to change the object being displayed (0 – 3F5).
- (b) This does not affect the displayed object and is not used in this game (0 – F).
- (c) This option Zooms the object larger (3FF) and smaller (0) (0 – 3FF).

5-3-8 ADS Screen

The Automatic Data System screen provides detailed game information such as length of time the machine has been on, the number of minutes the game has been played, the number of games played, the number of games continued...etc.. This screen can be useful in adjusting the game for maximum income.

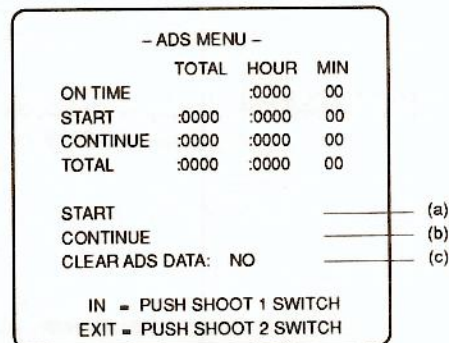

Illustration 5-10, ADS MENU SCREEN

- (a) Selecting the Start screen displays the number of first credit games and at what section of the game (section 1, 2, or end) the player died.
- (b) The Continue screen displays the number of games continued and which section the player continued from.
- (c) Selecting "YES" and pressing Trigger "1" will erase all the ADS results to date.

5-4 DIP Switches

The DIP switches are on the CPU-PCB of the Game PC boards (see section 7-5).

- Switch 1) Secondary Test Switch. Selects the test mode (see Section 5-3).
- Switch 2-7) Not used. Always off.

Switch 8) Screen Stop. When selected, the screen will stop whenever Trigger 3 is depressed. Some scenes cannot be stopped, however.

NOTE: When playing a game, all switches must be in the "OFF" position or the machine will not function properly.

5-5 Monitor Adjustment

The monitor remote adjustment control is attached to the left side of the monitor chassis.

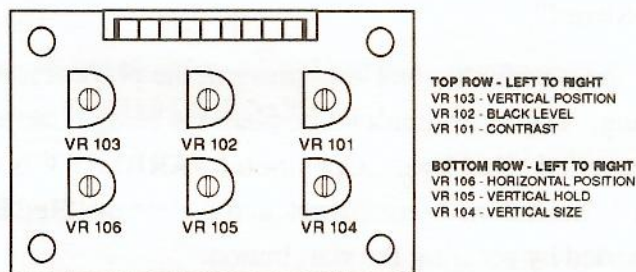

Illustration 5-11, MONITOR REMOTE ADJUSTMENT BOARD

5-6 Gun Adjustment

STARBLADE™ will not operate correctly if the game PC board, ROM, gun assembly, and the control potentiometers are not adjusted after being replaced.

Always carry out the steps listed below when replacing parts.

- 1) Open the coin box door.
- 2) Turn the test switch to the "ON" position while holding down the service switch. Screen 1 will appear.

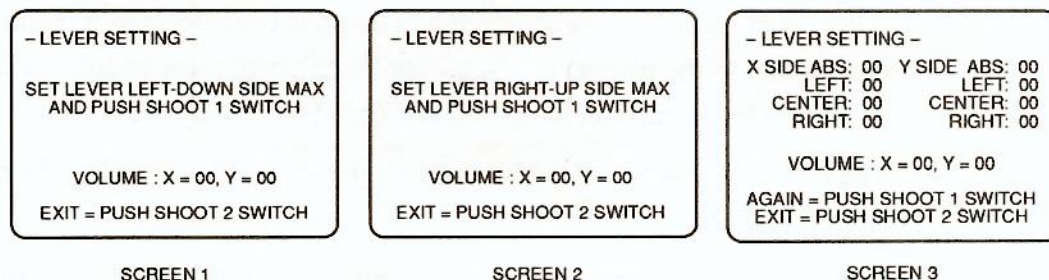

Illustration 5-12, GUN AIMING SCREENS

- 3) Adjust the gun as follows.
 - a. Aim the gun **down** and to the **left** as far as possible, and pull the right trigger. Screen 2 will appear.
 - b. Aim the gun **up** and to the **right** as far as possible, and pull the right trigger. Screen 3 will appear.
 - c. Compare the gun movement to the screen display. If everything is displayed correctly, press the right thumb button. If not, press the right trigger and readjust the potentiometers.

NOTE: If the gun aim does not line up with the line of shot displayed on the screen during game play, repeat the above procedure.

6. HOW TO PLAY

- STARBLADE™ is a 1st person **space combat simulator** that utilizes a hemispherical mirror to display various types of enemies which the player attempts to shoot with the gun.
- After inserting the proper coins, the player starts the game by pressing the start button. The player then becomes the U.G.S.F.'s top gunner in the flagship "GeoSword".
- Once the start button has been pressed, the player receives a short (45 second) briefing. The federation's home planet is being attacked by a mechanized planet called "Red Eye." Operation STARBLADE is to achieve two objectives; 1. defend the home planet, and 2. destroy "Red Eye". The briefing can be aborted by pressing the start button.
- After the briefing, the player and his ship (the FX-01 GeoSword) are then launched into space to defend his attack fleet and protect the mother planet. Every time the player is hit, the hit lamp (in the center of the gun) will flash and the shield power will be decreased. Most of the enemies shots can be destroyed before they can damage the GeoSword.
- The enemies retreat through warp space to "Red Eye" and the GeoSword is directed to breach the enemy defense barrier and destroy the mechanized planet.
- After "Red Eye's" power source (Octopus) has been destroyed (resulting in the destruction of the planet) the GeoSword then encounters additional fighters and an enemy battleship (Iceberg) and is ordered to destroy them.
- The battleship is eliminated by entering the ship and destroying the power source.
- While evacuating Iceberg, the GeoSword encounters the enemy commander and the player must destroy him.
- The object of the game is to shoot all the enemies and finish all three levels for the best possible score.
- For rapid fire, any one of the four (4) trigger buttons can be held down. All four buttons fire the same weapon so that players can use the buttons that are most comfortable for them.
- Once the player's shields run out the game ends, but the player can always continue.
- Players who finish the game with the highest scores can enter their initials into the Hall of Great Fighters.

7. MAINTENANCE

BE SURE TO TURN THE POWER OFF BEFORE CONDUCTING ANY MAINTENANCE PROCEDURES.

7-1 Marquee and Fluorescent Lamp Replacement

- 1) Using the wrench provided, remove the six (6) tamper proof screws holding the marquee acrylic in place.
- 2) Remove the marquee acrylic.
- 3) Replace the fluorescent lamp (20W) and/or the marquee.
- 4) Reverse these steps to reassemble.

7-2 Gun Assembly Replacement

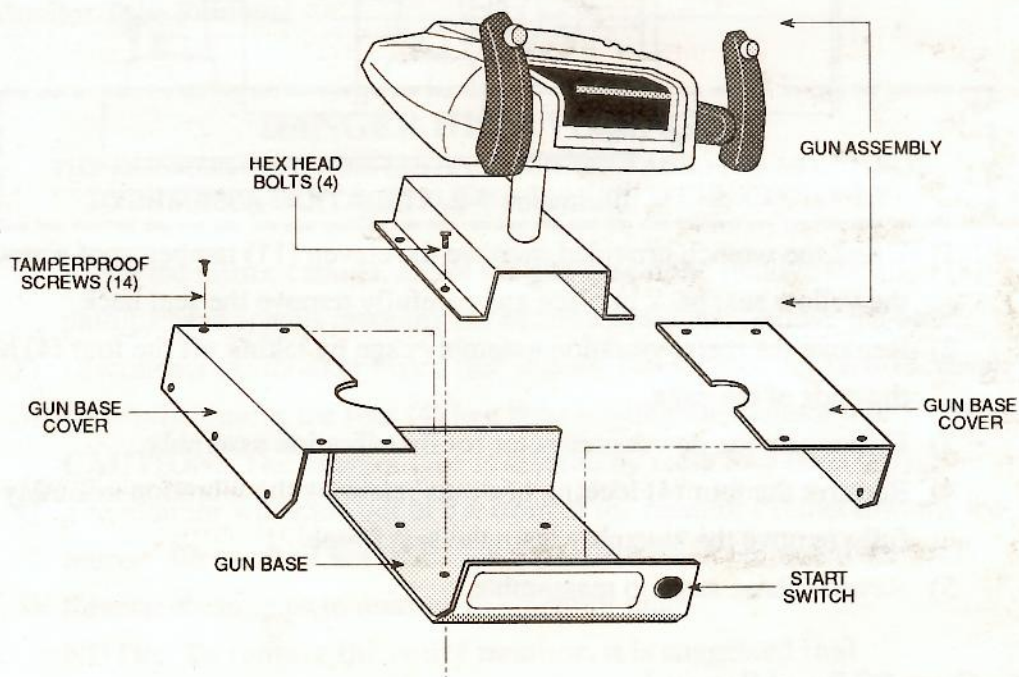

Illustration 7-1, GUN ASSEMBLY REPLACEMENT

- 1) Remove the fourteen (14) tamperproof screws holding the purple gun base covers (right and left side) in place, and carefully remove the covers.
- 2) Remove the one (1) phillips screw securing the ground wire to the side of the gun assembly.
- 3) Remove the four (4) hex head bolts holding the gun assembly to the purple gun base.
- 4) Carefully lift the gun assembly, disconnect the two (2) wire harness connectors and remove the assembly from the game.
- 5) Reverse these steps to reassemble.

7-3 Hemispherical Mirror Replacement and Cleaning

CAUTION: The mirror is easily scratched or damaged if not properly handled.

CLEANING: Use only 100% cotton or cheesecloth and a non-abrasive plastic cleaner.

- 1) Open the rear door and loosen the eight (8) screws of the lower four retaining brackets.
- 2) Remove the upper two retaining brackets.
- 3) Slowly lift the mirror up and out of the lower brackets to remove.

7-4 Vibration Assembly Replacement

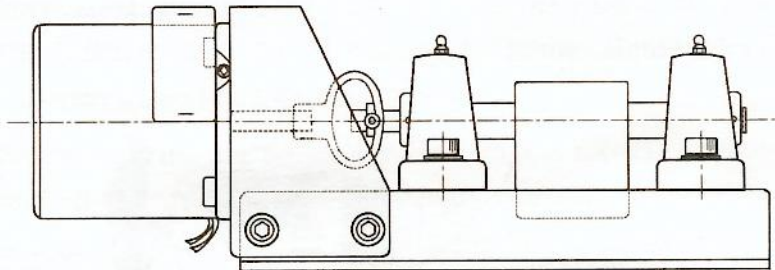

Illustration 7-2, VIBRATION ASSEMBLY

- 1) Using the wrench provided, remove the eleven (11) tamperproof screws holding the yellow seat back in place and carefully remove the seat back.
- 2) Remove the metal vibration assembly cage by taking off the four (4) hex nuts on the ends of the cage.
- 3) Disconnect the power connector for the vibration assembly.
- 4) Remove the four (4) locking hex nuts retaining the vibration assembly and carefully remove the assembly from the seat frame.
- 5) Reverse these steps to reassemble.

7-5 Game PC Board Removal

- 1) Insure that the game is unplugged.
- 2) Carefully open the lower back door.
- 3) Disconnect the power leads (on the bottom of the PCB cage) and the main harness connector (on the top of the PCB cage).
- 4) Remove the four (4) phillips head screws (2 on each side) mounting the PCB cage to the rear door.
- 5) Remove the four (4) phillips head screws (1 on each corner) securing the cage lid to the PCB cage and carefully remove the lid.
- 6) The four (4) PCBs can be removed individually by sliding them straight out of the cage.
- 7) Reverse these steps to reinstall the PCBs and PCB cage.

7-6 Monitor Board Access

DANGER HIGH VOLTAGE

THE MONITOR CONTAINS LETHAL HIGH VOLTAGE. THE MONITOR IS TO BE SERVICED BY A QUALIFIED SERVICE TECHNICIAN ONLY.

You will need a ladder or step stool to remove the monitor board. Remember to use caution when standing on or climbing any ladder.

- 1) Remove the six (6) phillips head screws securing the uppermost panel on the top of the monitor cabinet and remove the panel.
- 2) The monitor board can only be accessed from the top of STARBLADE™.

7-7 Monitor Tube Removal

DANGER HIGH VOLTAGE

THE MONITOR CONTAINS LETHAL HIGH VOLTAGE. THE MONITOR IS TO BE SERVICED BY A QUALIFIED SERVICE TECHNICIAN ONLY.

- 1) Inside the mirror cabinet, above the gun assembly, remove the eight (8) phillips head screws retaining the monitor bezel and remove the bezel.
- 2) Disconnect the monitor board (see section 7-6 for monitor board access).
- 3) Carefully remove the four (4) hex bolts holding the monitor tube in place.
CAUTION: The monitor tube is secured by these four bolts **only**.
- 4) The monitor will slide out of the front of the monitor cabinet towards the mirror. Be cautious not to scratch the mirror when removing the CRT.
- 5) Reverse these steps to reinstall the monitor tube.

NOTE: To remove the entire monitor, it is suggested that STARBLADE™ be disassembled first to remove the monitor safely.

7-8 Strobe Lamp Replacement

- 1) Open the upper rear door and unplug the harness for the strobe assembly to be removed.
- 2) Using the wrench provided, remove the three (3) tamperproof screws holding the acrylic strobe cover in place.
- 3) Remove the two (2) phillips head screws holding the strobe assembly bracket in place.
- 4) There are three (3) small phillips head screws on the back of the assembly that attach the strobe light to the bracket.
- 5) Reverse the above steps to reinstall the strobe assembly.

8. TROUBLESHOOTING

If you suspect the game may be malfunctioning, the following steps should be considered before you make a service request.

- (1) The power supply should be between 110-120 Volts AC. However, when some other equipment (air conditioners, multiple pinball games, air compressors, etc.) are connected to the same power source, the voltage may change beyond this range and cause game trouble or improper operation. To guard against this, each STARBLADE™ Cabinet should have its own dedicated power source.
 - (2) When the game does not work with the power turned on, turn the power off once and then back on. This may restart the game. If it still does not work, inspect the fuses.
 - (3) When the game PCB, the ROMs, the Gun Assembly, or the Potentiometers are replaced, it is necessary to make adjustment for the game to function normally. Make appropriate adjustments referring to section 5-6, Gun Adjustment.
 - (4) If the gun aim does not line up with the line of shot displayed on the screen, refer to section 5-6, Gun Adjustment.
 - (5) Check all wiring connections as malfunctions can be caused by loose connections.
 - (6) Foreign substances, including dust, on the game PCB or on the monitor PCB, may cause malfunctions or improper operation. Check that the PCBs are clean.
 - (7) When you make electrical checks, use the wiring diagrams for reference.
- * If the above suggestions are not applicable, or no improvement is observed, contact your distributor or the service office printed on the back cover of this manual.
 - * **DO NOT ATTEMPT TO REPAIR THE GAME PCB YOURSELF.** Instead, please return the board to your distributor for any repairs. This PCB contains sensitive devices that could be destroyed even by the internal voltage of a multi-meter.
 - * When sending parts to be repaired, make sure to pack them firmly with a complete explanation of the problem. When sending PCBs, package them in anti-static foam or bubble wrap, and pack them in cardboard boxes to protect against impact damage during shipment. To ship monitors, pack them in wooden frames so that CRTs and PCBs are protected against impact.

Parts List

9. PARTS LIST

TOP ASSEMBLY SB02-00288-00		
ITEM	DESCRIPTION	PART NO.
1	Mirror Cabinet Assembly	SB05-00291-00
2	Mirrorized Hemisphere	SB90-00317-00
3	Monitor Cabinet Assembly	SB05-00292-00
4	Plastic Mirror Bezel, Top	SB95-00302-00
5	Plastic Mirror Bezel, Bottom	SB95-00302-01
6	Isolation Mount Cover	SB95-00302-02
7	Strut Cover	SB95-00302-03
8	Namco Strobe Assembly	SB03-00293-00
9	Vibrating Seat Frame Assembly	SB05-00298-00
10	Seat Base Assembly	SB05-00299-00
11	Over/Under Coindoor	VG83-00045-00
12	Namco System 21 PCB Assy.	SB03-00297-00
13	Namco Hit PCB Assembly	SB03-00296-00
14	Namco SB Gun Assembly	SB04-00295-00
15	Graphics Kit Assembly	SB05-00301-00
16	25 Inch Standard Monitor	VG85-00358-00
17	Isolation Transformer	VG56-00245-00
18	Isolation Transformer	VG56-00174-00
19	2 Amp Quick Acting Fuse	VG52-00477-00
20	0.2 Amp Quick Acting Fuse	VG52-00478-00
21	Plastic 25" Monitor Bezel	SB95-00303-00
22	Fluorescent Lamp Assembly	VG57-00058-00
23	80 CFM Fan	VG55-00060-00
24	Fan Guard	VG55-00061-00
25	Speaker, 5"	VG54-00062-00
26	Speaker Grill	VG10-00485-00
27	XT Type Power Supply	VG88-00080-00
28	Ferrite Clamp (FCC)	VG78-00198-00
29	Ferrite Housing (FCC)	VG78-00199-00

TOP ASSEMBLY (cont.)		
ITEM	DESCRIPTION	PART NO.
30	Clear Acrylic Strobe Cover	SB95-00315-00
31	Push Button, Purple	VG80-00316-00
32	EMI Line Filter (FCC)	VG78-00476-00
33	STARBLADE™ Speaker Grill	SB10-00318-00
34	Well Nut Threaded Insert	VG20-00486-00
35	Top Tube Mount Plate	SB10-00489-00
36	Monitor Box Support	SB10-00490-00
37	Mirror Mounting Bracket	SB10-00491-00
38	Top Monitor Bracket	SB10-00492-00
39	Monitor Box Support	SB10-00493-00
40	Kick Diamond Plate	SB10-00494-00
41	Strobe Mount Bracket	SB10-00495-00
42	Fuse Holder S-8202-2 (UL)	VG52-00496-00
43	Label, 0.2 Amp Fuse (UL)	VG52-00477-00
44	Label, 2 Amp Fuse (UL)	VG52-00478-00
45	Spacer #41 (UL)	VG10-00497-00
46	Cord Clip ACC38-A-M (UL)	VG51-00498-00
47	Enclosure Coin Housing	VG10-00465-00
48	Plate Door Lock	VG10-00446-00
49	Bracket, Power Supply Mount	VG10-00499-00
50	Box, Plastic Cash	VG90-00466-00
51	Cover, Serial	VG95-00500-00
52	Strobe Light Window	SB95-00501-00
53	Bag, 40 x 34 x 81 Plastic	VG60-00502-00
54	Lamp F15T8GW	VG57-00059-00
55	STARBLADE™ Plastic Marquee	SB90-00324-00
56	Strut Mounting Plate	SB10-00375-00
57	Enclosure, Transformer	SB10-00526-00
58	Cover Under Wire	SB10-00527-00

9. PARTS LIST (cont.)

SHIPPING ASSEMBLY SB01-00286-00		
ITEM	DESCRIPTION	PART NO.
1	Product Carton	SB60-00287-00
2	STARBLADE™ Top Assembly	SB02-00288-00
3	Operator's Manual	SB45-00289-00
4	FCC Notice	VG46-00031-00
5	Serial Number Label	F246-00032-00
6	UL Label	VG46-00065-00
7	Manual Poly Bag	VG60-00098-00
8	Game Poly Bag	VG60-00017-00
9	Shipping Label Namco	SB46-00488-00
10	Box, Seat Frame	SB60-00487-00
11	Box, Monitor	SB60-00505-00

GRAPHICS KIT ASSEMBLY SB05-00301-00		
ITEM	DESCRIPTION	PART NO.
1	Marquee Acrylic Panel	SB40-00389-00
2	Side Decal, Top Right	SB40-00395-00
3	Side Decal, Top Left	SB40-00394-00
4	Overhead Decal	SB40-00396-00
5	Control Panel Overlay	SB40-00399-00
6	Monitor Cabinet Decal, Left	SB40-00393-00
7	Monitor Cabinet Decal, Right	SB40-00392-00
8	Seat Back Panel, Top	SB40-00398-00
9	Seat Back Panel, Bottom	SB40-00397-00
10	Side Decal, Bottom, Left	SB40-00391-00
11	Side Decal, Bottom, Right	SB40-00390-00
12	Front Top Left	SB40-00474-00
13	Front Top Right	SB40-00475-00

HARNESS ASSEMBLY SB05-00528-00		
ITEM	DESCRIPTION	PART NO.
1	Main Wire Harness	SB50-00509-00
2	DVAV Ext.	SB50-00510-00
3	Gun Wire Harness	SB50-00511-00
4	Monitor Light Wire Harness	SB50-00512-00
5	Speaker Motor Wire Harness	SB50-00513-00
6	Motor Ext. Wire Harness	SB50-00514-00
7	Start Ext. Wire Harness	SB50-00515-00
8	Power Ext. Wire Harness	SB50-00516-00
9	Speaker Ext. Wire Harness	SB50-00517-00
10	Gun Ext. Wire Harness	SB50-00518-00
11	TSA Bracket Wire Harness	SB50-00519-00
12	Coin Door Wire Harness	SB50-00520-00
13	Lamp Pigtail	SB50-00521-00
14	IBM Power Cord Mod.	SB50-00522-00
15	Monitor Ext.	SB50-00523-00
16	#6 Spade	SB50-00524-00

MIRROR CABINET ASSEMBLY SB05-00291-00		
ITEM	DESCRIPTION	PART NO.
1	Mirror Cabinet	SB63-00371-00
2	Color T Mold 25/32	VG90-00372-00
3	Caster, 360 Swivel	VG24-00373-00
4	Lock 2255	VG83-00165-00
5	Leveler Plate	SB10-00507-00
6	Bottom Door Hinge	SB10-00506-00

9. PARTS LIST (cont.)

VIBRATING SEAT ASSEMBLY SB05-00298-00

ITEM	DESCRIPTION	PART NO.
1	Namco Vibrating Assembly	SB04-00294-00
2	Seat Frame	SB10-00376-00
3	Hunsaker Seat	DV90-00092-00
4	Plastic STARBLADE™ Seat Back	SB90-00378-00
5	Rubber Isolation Mount	SB04-00380-00
6	Control, Left Top Panel	SB10-00400-00
7	Control, Right Top Panel	SB10-00401-00
8	Control, Bottom Bracket	SB10-00402-00
9	Seat Bottom Bracket	SB10-00406-00
10	Diamond Strip Protection	SB10-00479-00
11	Diamond Plate	SB10-00480-00
12	Frame Support Bracket	SB10-00481-00
13	Tube	SB10-00482-00
14	Bottom Mounting Plate	SB10-00483-00
15	End Caps	SB10-00484-00
16	Caster, 360 Swivel	VG24-00373-00
17	Isolation Mount Nut	SB20-00503-00
18	Isolation Mount Washer	SB20-00504-00

NAMCO SYSTEM 21 PCB ASSEMBLY SB03-00297-00

ITEM	DESCRIPTION	PART NO.
1	EMI PCB	SB03-00361-00
2	CPU PCB	SB03-00362-00
3	PGN (B) PCB	SB03-00363-00
4	DSP PCB	SB03-00364-00
5	OBJ PCB	SB03-00365-00
6	MOTHER PCB	SB03-00366-00
7	AMP (B) PCB	SB03-00367-00
8	DRIVE PCB	SB03-00368-00
9	Metal Chassis	SB03-00369-00
10	Metal EMI Panel	SB03-00370-00

SEAT BASE ASSEMBLY SB05-00299-00

ITEM	DESCRIPTION	PART NO.
1	Strut Mounting Plate	SB10-00375-00
2	Pool Leg Foot	VG20-00384-00
3	Tube	SB10-00482-00

SERVICE PANEL ASSEMBLY VG05-00314-00

ITEM	DESCRIPTION	PART NO.
1	Coin Counter	VG83-00166-00
2	Service Panel, STARBLADE™	VG10-00387-00

MONITOR CABINET ASSEMBLY SB05-00292-00

ITEM	DESCRIPTION	PART NO.
1	Monitor Cabinet	SB63-00374-00
2	Color T Mold 5/8	VG90-00508-00

9. PARTS LIST (cont.)

9-1 Vibration Assembly

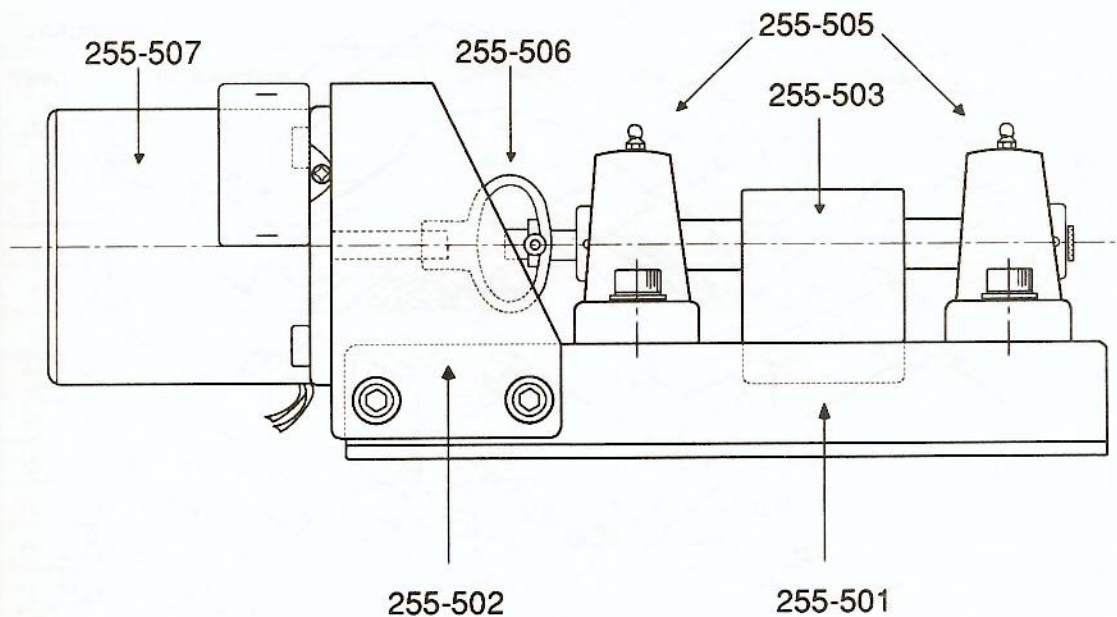

NAMCO VIBRATING ASSEMBLY SB05-00298-00		
ITEM	DESCRIPTION	PART NO.
1	Vibrator Base	255-501
2	Motor Bracket	255-502
3	Weight	255-503
4	Pillow Block UCP201	255-505
5	K-Coupling 5802 (10x10)	255-506
6	Reversible Motor, 5RK40A-A	255-507

9. PARTS LIST (cont.)

9-2 Gun Assembly

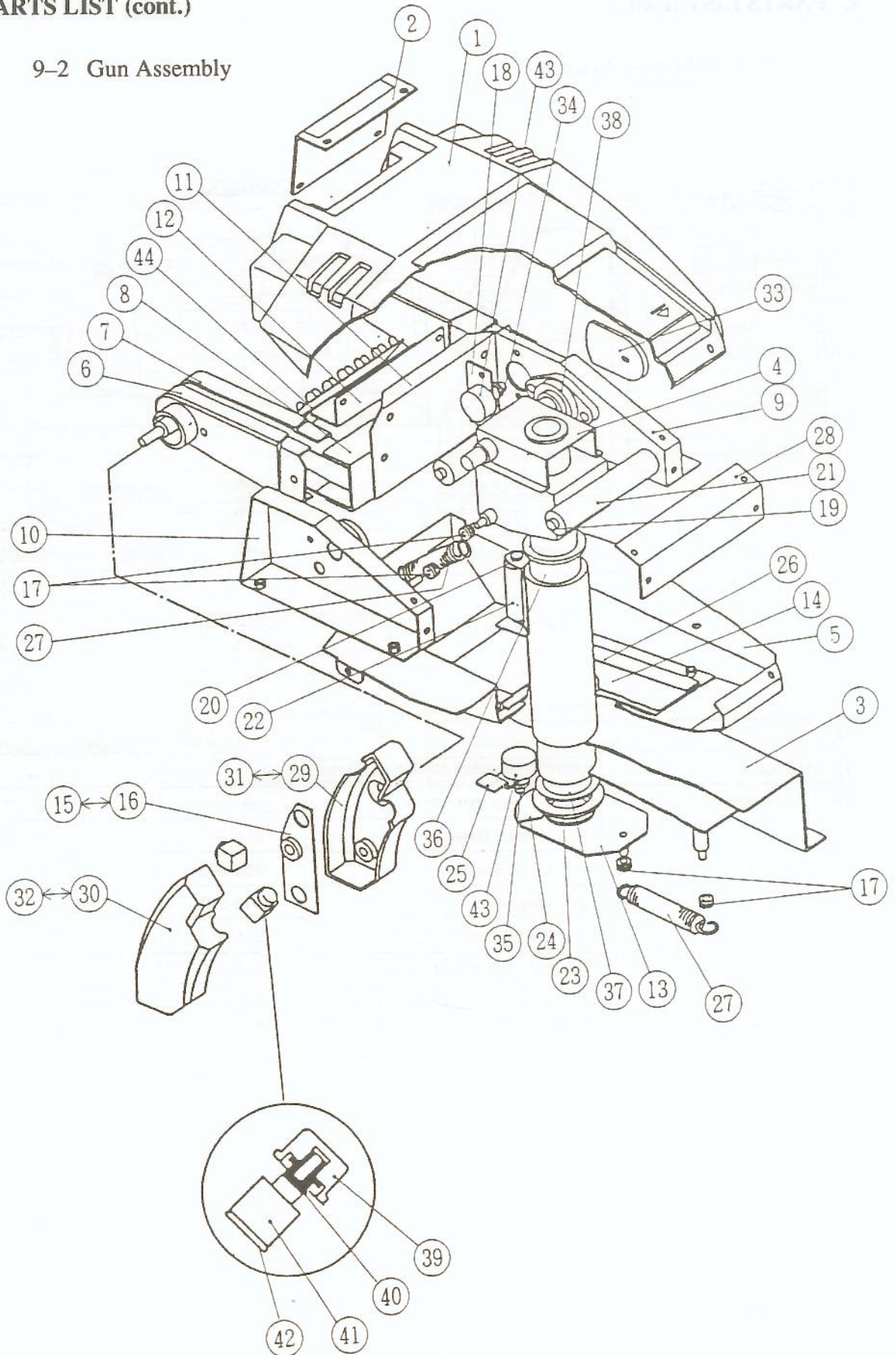

9. PARTS LIST (cont.)

GUN ASSEMBLY		
ITEM	DESCRIPTION	PART NO.
1	Controller Cover	255-601
2	Indicator Cover	255-602
3	Neck	255-603
4	Core Shaft	255-604
5	Bottom	255-605
6	Outside Cover	255-606
7	Inside Cover	255-607
8	Arm	255-608
9	Frame (Left)	255-609
10	Frame (Right)	255-610
11	Frame (Front)	255-611
12	LED Bracket	255-612
13	Pipe End	255-613
14	Slide Plate	255-614
15	Grip Plate (Left)	255-615
16	Grip Plate (Right)	255-616
17	Roller	255-617
18	Volume Plate	255-618
19	Pipe Stay (P)	255-619
20	Pipe Stay (Y)	255-620
21	Stopper Rubber (P)	255-621
22	Stopper Rubber (Y)	255-622

GUN ASSEMBLY (continued)		
ITEM	DESCRIPTION	PART NO.
23	Spacer	255-623
24	Spur Gear (Y)	255-624
25	Volume Bracket	255-625
26	Slide Hole	255-626
27	T Spring (A)	255-627
28	Angle	255-628
29	Grip (RA-SB)	255-629
30	Grip (RB-SB)	255-630
31	Grip (LA-SB)	255-631
32	Grip (LB-SB)	255-632
33	Gear	246-140
34	Spur Gear (S76B20B+0306)	231-093
35	Spur Gear (S75B32B+0306)	231-633
36	EP Bushing (LFF-3220)	255-634
37	EP Bushing (LFF-3020)	255-635
38	Rhombic Flange Unit (UF1001)	255-636
39	Button	244-009
40	Button Joint	244-029
41	KB Switch	000-055
42	KB Sub PC Board (B)	224-030
43	Volume EWS-UOA20E53	008-006
44	Hit PCB	255-637

9. PARTS LIST (cont.)

9-3 Coin Control Assembly

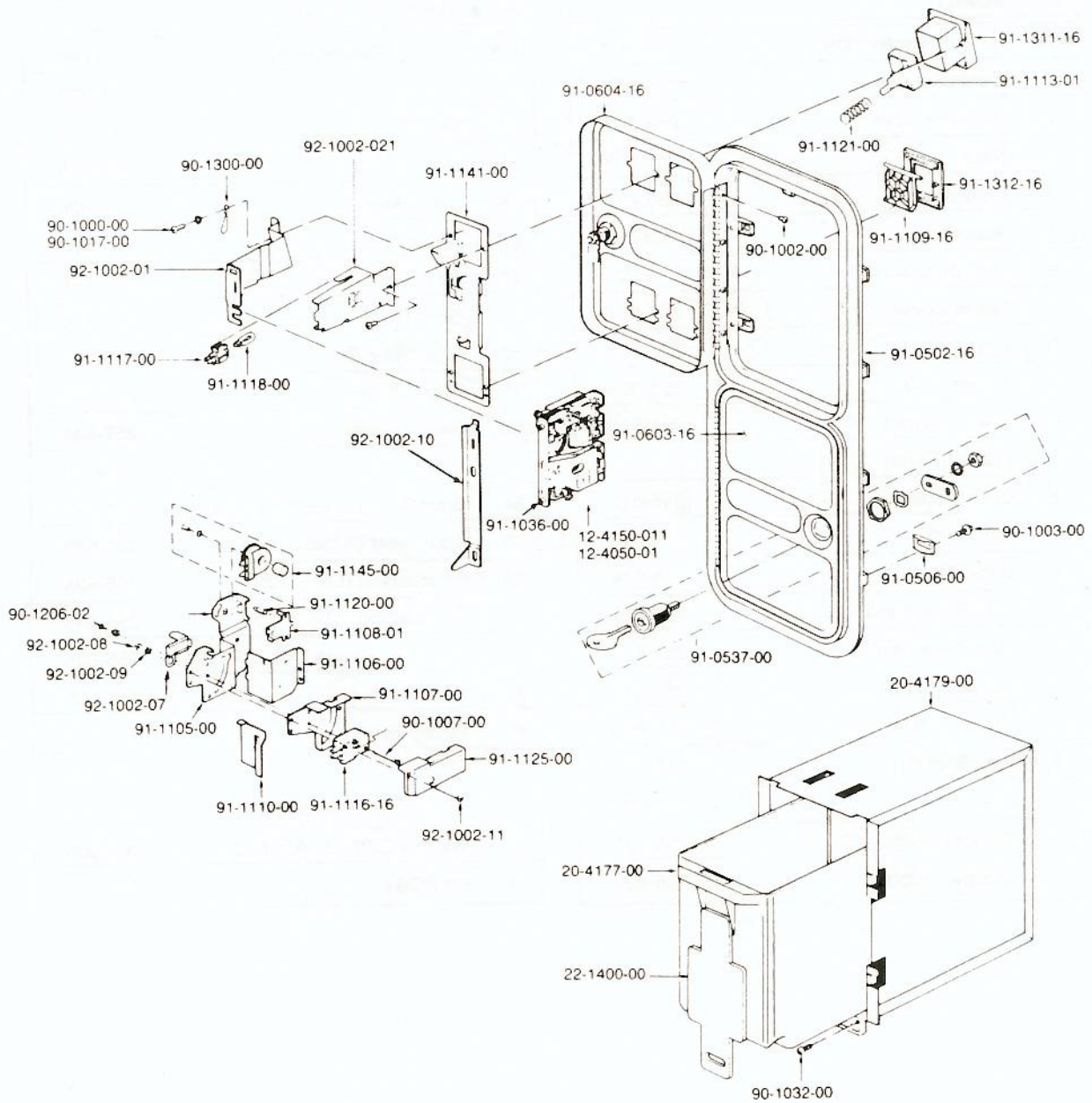

COIN CONTROLS COIN DOOR ASSEMBLY

Wiring Harness Diagram

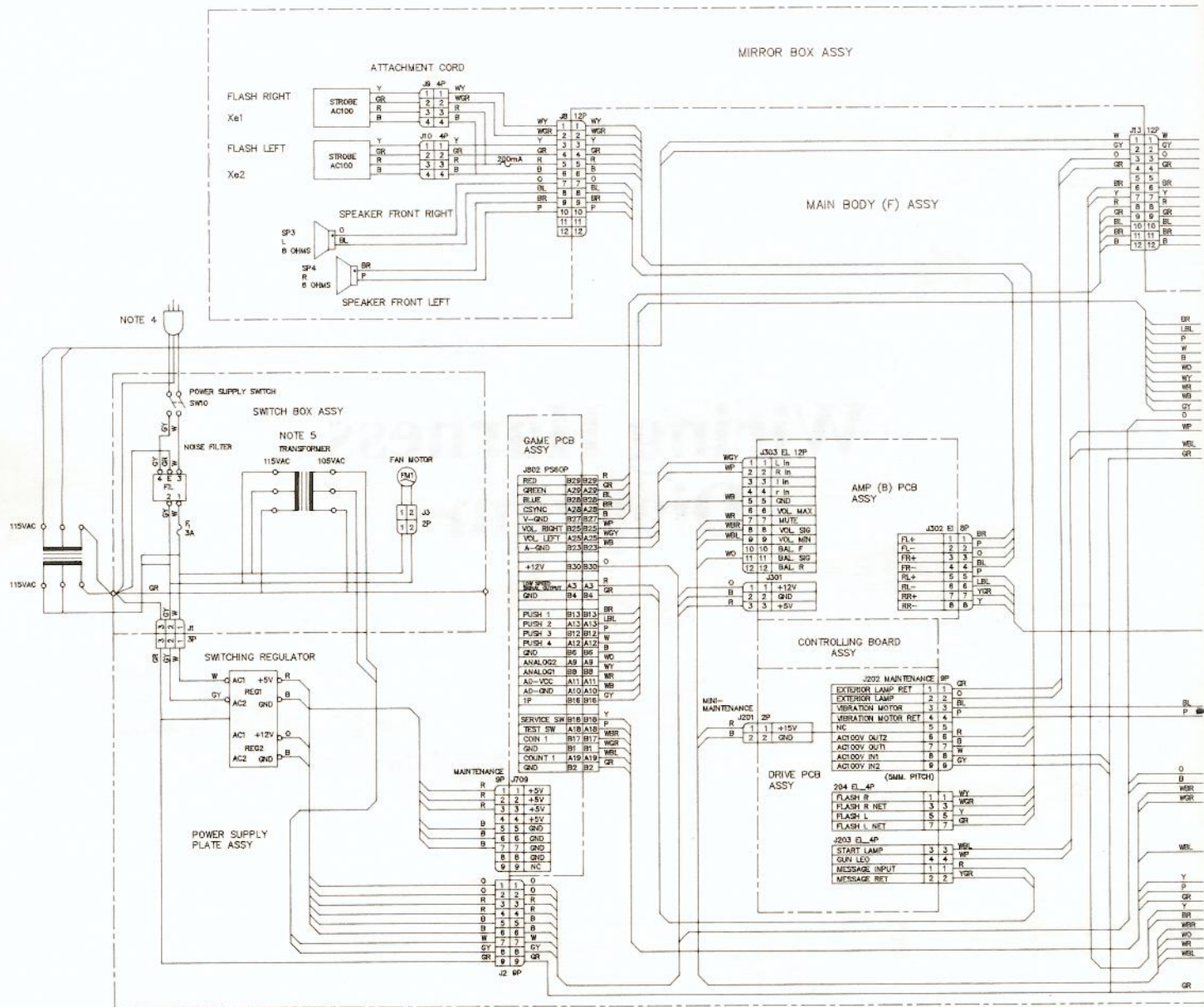

COLOR ABBREVIATION:

BLACK	=	B
RED	=	R
BLUE	=	BL
ORANGE	=	O
YELLOW	=	Y
GRAY	=	GY
BROWN	=	BR
GREEN	=	GR
WHITE	=	W
LIGHT BLUE	=	LBL
PINK	=	P

NOTES:

- CONNECTOR UNLESS OTHERWISE SPECIFIED, INDICATE MINI UNIVERSAL MAINTAIN LOCK.
- APPLY SOCKET CONTACT FOR PLUG CONNECTOR, AND PIN CONTACT FOR CAP CONNECTOR.
- THIN LINES UNLESS OTHERWISE SPECIFIED, INDICATE AWG24 AND THICK LINES AWG18.
- 3 CORE TIRE CORD WITH PLUG.
- TAB OF TRANSFORMER INDICATES 240,220,200V, OR 120, 115,110V RESPECTIVELY. ADJUST ITS CONNECTION FOR INPUT POWER VOLTAGE.
- APPLY 3A FUSE FOR 200V,240V AND 5A FUSE FOR 110V, 120V.

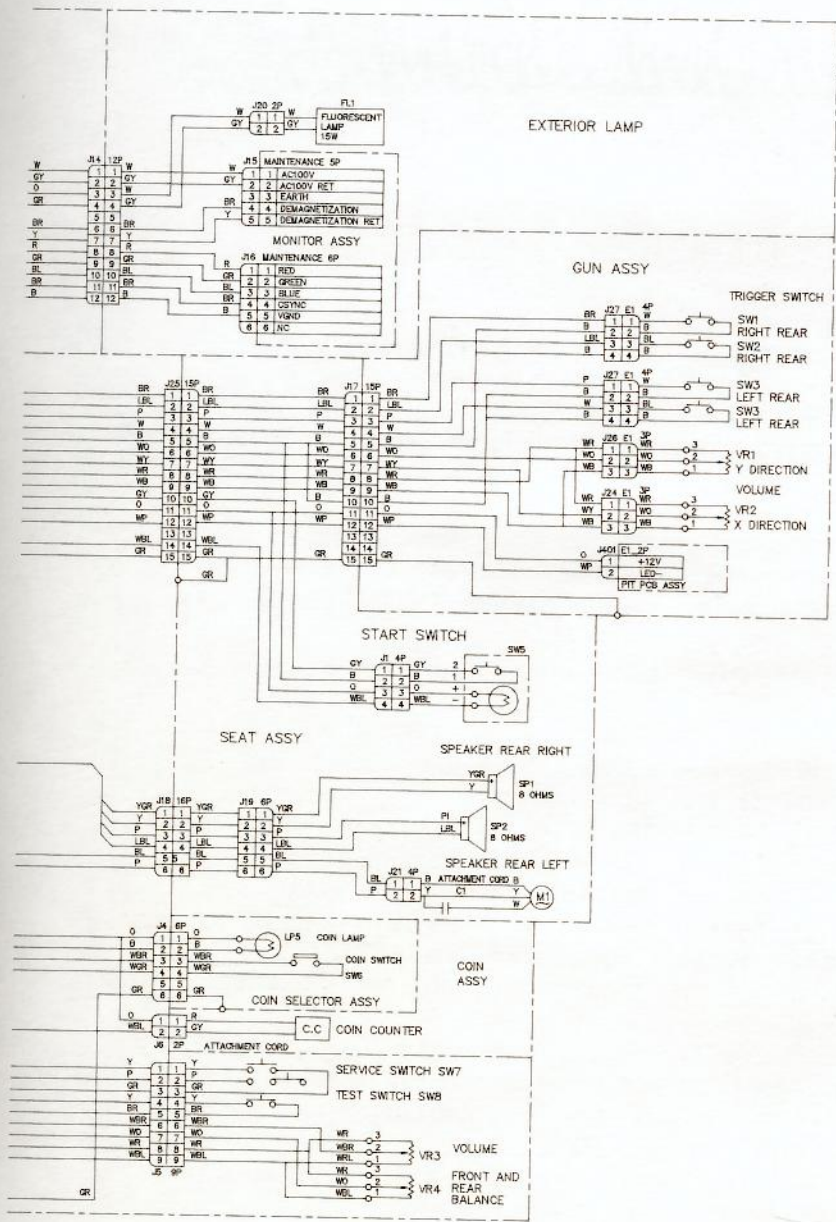

COLOR ABBREVIATION:

- | | |
|------------|------------------|
| BLACK = B | BROWN = BR |
| RED = R | GREEN = GR |
| BLUE = BL | WHITE = W |
| ORANGE = O | LIGHT BLUE = LBL |
| YELLOW = Y | PINK = P |
| GRAY = GY | |

namco[®]

NAMCO-AMERICA, INC.

3255-1 Scott Blvd., Suite 102
Santa Clara, CA 95054-3013

(408)496-6371

FAX: (408)496-6399

Reorder Number SB45-00289-00

WWW.DRAGONSLAIRFANS.COM